

Mach7 Enterprise Imaging Platform v12.0.0 DICOM Conformance Statement

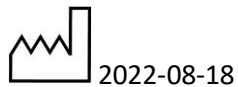

Manufacturer:

Mach7 Technologies, Inc.
120 Kimball Avenue, Suite 210
South Burlington, VT 05403
USA

+1 802 861 7745 – phone
+1 802 861 7779 – fax



0459

© 2022 MACH7 Technologies



European Authorized Representative:

Emergo Europe
Prinsessegracht 20
2514 AP
The Hague, Netherlands
+31.70.345.8570 - phone
+31.70.346.7299 - fax

All rights reserved. No parts of this work may be reproduced in any form or by any means -graphic, electronic, or mechanical, including photocopying, recording, taping, or information storage and retrieval systems without the written permission of the publisher. Products that are referred to in this document may be either trademarks and/or registered trademarks of the respective owners. The publisher and the author make no claim to these trademarks. While every precaution has been taken in the preparation of this document, the publisher and the author assume no responsibility for errors or omissions, or for damages resulting from the use of information contained in this document or from the use of programs and source code that may accompany it. In no event shall the publisher and the author be liable for any loss of profit or any other commercial damage caused or alleged to have been caused directly or indirectly by this document.

Technical Support

For technical queries, write to support@mach7t.com

General Enquiries

For general enquiries, write to info@mach7t.com

Contact MACH7 Technologies

Americas Sales & Service

Mailing Address:

PO Box 586

Burlington, VT 05402

Office Location:

120 Kimball Avenue, Suite 210

South Burlington, VT 05403

T: +1-888-87-MACH7 (Toll Free USA only)

T: +1-802-861-7745

F: +1-802-861-7779





Contents

About this Conformance Statement.....	6
Symbols Used	6
Cautions	6
Introduction	6
Intended Audience	6
Acronyms	6
Release History.....	7
Implementation Model.....	9
General	9
Application Data Flow Diagram.....	9
Functional Definitions.....	13
Mach7 Enterprise Imaging Platform DICOM Workflow.....	14
Application Entity Specification	16
Mach7 Enterprise Imaging Platform AE Specification	16
Query/Retrieve Specifications.....	21
Printing Specifications	22
WADO-URI Specifications	22
WADO-RS Specifications	23
QIDO-RS Specifications	25
Association Establishment Policies.....	27
General.....	27
Asynchronous Nature	27
Implementation Identifying Information.....	27
Association Initiation Policy	27
Associated Real-World Activities.....	27
Receive Images from Remote Node	27
Respond to a Query/Retrieve Request.....	27
Respond to a Storage Commitment Request.....	28
Proposed Presentation Contexts.....	28
SOP Specific Conformance for Query/Retrieve Service Class	29
Communication Profiles	30

TCP/IP	30
Physical Media Support	30
Support of Extended Character Sets	30

About this Conformance Statement

Symbols Used

	Manufacturer name
	European Authorized Representative
	Consult Instructions for Use.
	Year of Manufacturer
	Caution

Cautions



Federal (USA) law restricts this device to sale by or on the order of a physician or medical institution.

Introduction

The DICOM Conformance Statement specifies the DICOM 3.0 service classes, information objects and communication protocols supported by Mach7 Enterprise Imaging Platform v11.8.

Intended Audience

This conformance statement is intended for system administrators who wish to evaluate Mach7 Enterprise Imaging Platform's DICOM conformance in precise terms as defined by NEMA standards.

Acronyms

- ACR-NEMA: American College of Radiology – National Electrical Manufacturer's Association
- AE: Application Entity
- ANSI: American National Standards Institute
- API: Application Programming Interface
- CT: Computed Tomography
- DICOM: Digital Imaging and Communications in Medicine
- DIMSE: DICOM Message Service Element
- FDDI: Fiber Distributed Data Interface
- LAN: Local Area Network

- MRI: Magnetic Resonance Imaging
- NM: Nuclear Medicine
- RF: Radio Fluoroscopy
- SC: Secondary Captured image
- SCP: Service Class Provider
- SCU: Service Class User
- SOP: Service Object Pair
- TCP/IP: Transport Control Protocol / Internet Protocol
- UID: Unique Identifier
- US: Ultra Sound
- UTF-8: Unicode Transformation Format 8
- WAN: Wide Area Network

Release History

Release Version	Release Date	Sections Affected	Description
11.7.2 LR1	June 2016	General Release	This is the general release of this statement for the Mach7 Enterprise Imaging Platform v11.7.2 LR 1.
11.7.2 GR	April 2017	General Release	This is the general release of this statement for the Mach7 Enterprise Imaging Platform v11.7.2 GR.
11.8.3	November 2018	QIDO-RS Specifications	This statement has been updated to include the Mach7 specifications for QIDO-RS conformance.
11.8.4	August 2019	General Release	This is the general release of this statement for Mach7 Enterprise Imaging Platform v11.8.4

Release Version	Release Date	Sections Affected	Description
11.9.0	July 2020	Mach7 Enterprise Imaging Platform AE Specification	Added additional supported SOP Classes to the Conformance to SOP Classes... table.
11.9.1	January 2021	Associated Real-World Activities – Proposed Presentation Contexts	Added JPEG Baseline to list of supported Transfer Syntaxes for Proposed Presentation Contexts.
12.0.0	August 2022	Associated Real-World Activities – Proposed Presentation Contexts Mach7 Enterprise Imaging Platform AE Specification	Updated list of supported Transfer Syntaxes for Proposed Presentation Contexts. Updated list of supported SOP Classes.

Implementation Model

General

Mach7 Enterprise Imaging Platform is a family of applications that interface to DICOM systems (e.g., modalities, PACS, film scanners, post-processing workstations, etc.) that are network connected. Mach7 Enterprise Imaging Platform applications receive and send image data in DICOM standard format. Certain Mach7 Enterprise Imaging Platform applications can store image data in a vendor neutral image archive. Other Mach7 Enterprise Imaging Platform applications provide storage maintenance tools that help the system administrator manage the image data.

Mach7 Enterprise Imaging Platform provides the following DICOM capabilities:

- DICOM 3.0 compliant C-STORE SCP for receiving images.
- DICOM 3.0 compliant C-FIND SCP for attribute matching.
- DICOM 3.0 compliant C-MOVE SCP for sending query keys to an SCP and awaiting responses.
- DICOM 3.0 compliant C-GET to fetch the information for one or more information objects.
- DICOM 3.0 compliant C-ECHO SCP for DICOM network connectivity verifications.
- DICOM 3.0 compliant Storage Commitment SCP
- DICOM 3.0 compliant C-STORE SCU for background image data store operations.
- DICOM 3.0 compliant C-ECHO SCU for DICOM communication connectivity verifications.

	Mach7 Archive	Mach7 Engine	Mach7 Clinical Viewer	Mach7 Study Import Utility
SCP/SCU	SCP	SCU	N/A	SCU
C-STORE	YES	YES	N/A	N/A
C-ECHO	YES	N/A	N/A	YES
C-FIND	YES	N/A	N/A	N/A
C-MOVE	YES	N/A	N/A	YES

N/A = Not Applicable

Application Data Flow Diagram

Mach7 Enterprise Imaging Platform provides Query/Retrieve and storage services for DICOM 3.0 standard images using C-ECHO, C-FIND, C-MOVE and C-STORE DIMSE-C Services. Mach7 Enterprise Imaging Platform provides Storage Commitment SCP using DIMSE-N Services.

As described below, when a C-STORE request is received and it has passed the access control, Mach7 Enterprise Imaging Platform creates a dedicated thread to deal with the request. It receives the image data and stores the relevant image data in a Mach7 Enterprise Imaging Platform database. When a C-ECHO request is received, Mach7 Enterprise Imaging Platform replies with a C-ECHO response to indicate its existence.

When a Query/Retrieve request is received and it has passed the access control, Mach7 Enterprise Imaging Platform creates a dedicated thread to deal with the request. It parses the identifier data and dynamically constructs a SQL query to retrieve data from the database, or it passes the request to a 3rd party image archive. When it receives data from the database or a remote server, Mach7 Enterprise Imaging Platform sends the data back to the requester with a response data package. Each data object will be wrapped with a response package. It repeats the responses until all of the retrieved data objects are sent.

When an operation raises a demand to send an image to a remote machine, Mach7 Enterprise Imaging Platform initiates a C-STORE request accordingly. The image data is transmitted to the requested remote machine along with the request. This operation is performed in the background.

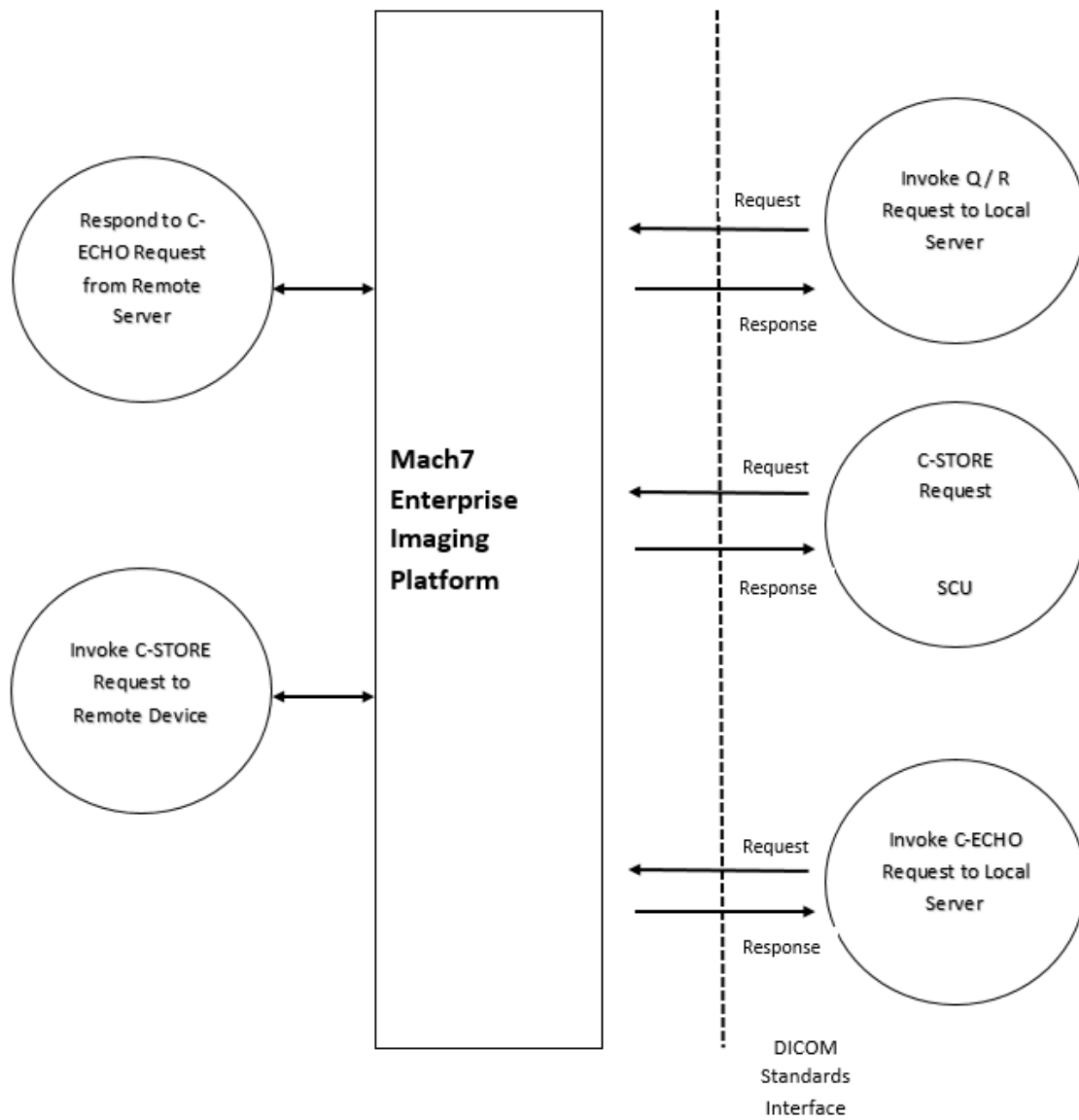

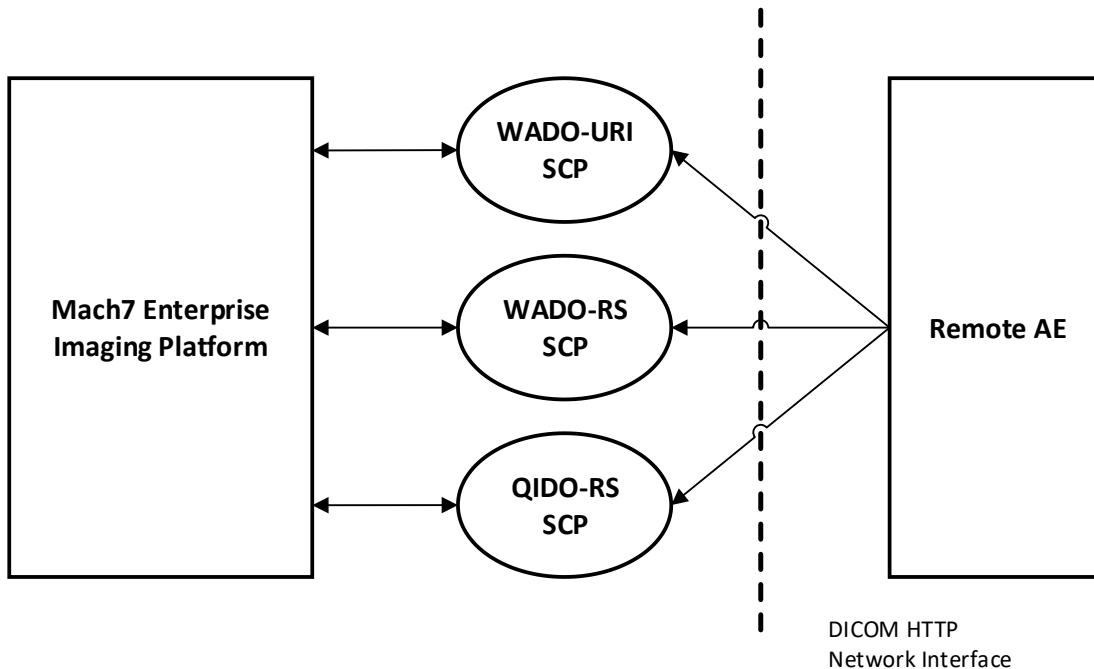
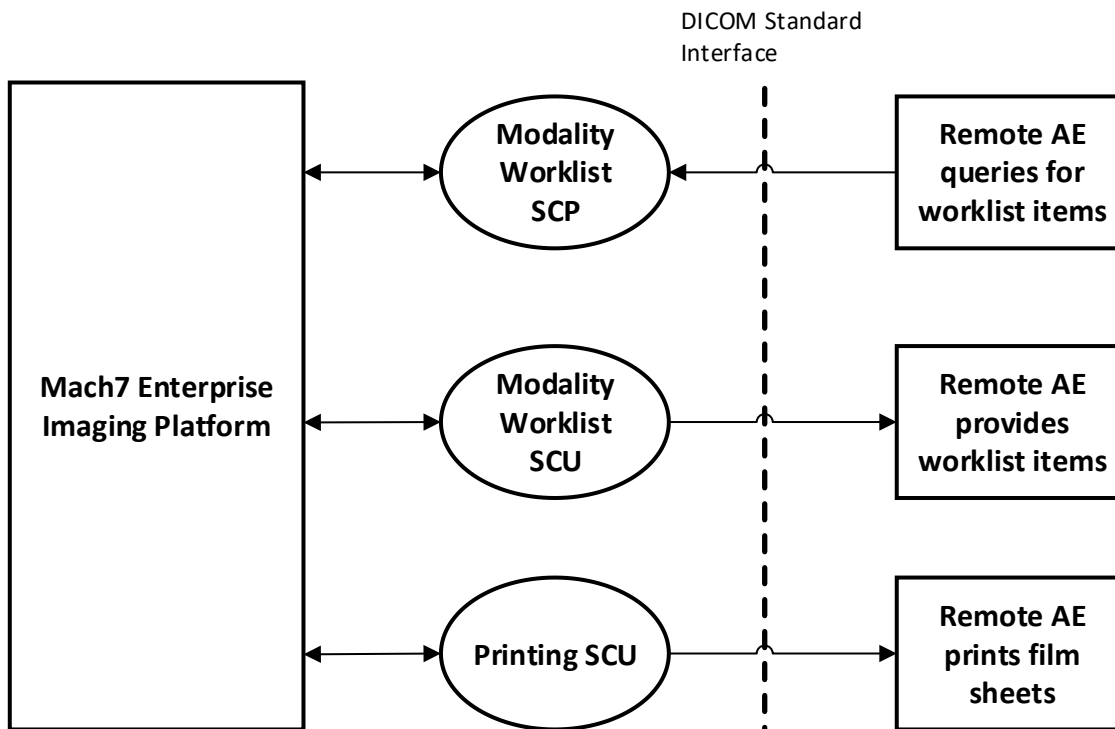

Functional Definitions

This section describes the verification, query, and transfer functions performed by Mach7 Enterprise Imaging Platform.

C-STORE SCP – The DICOM image receiver is initialized as a standalone resident program when Mach7 Enterprise Imaging Platform is started. The DICOM receiver waits for a remote AE to request a connection at the presentation address configured for its AE Title. The presentation address of the DICOM receiver consists of the system IP address, AE Title, and communications port. The AE Title and communication port for the DICOM receiver is user configurable in Mach7 Enterprise Imaging Platform. The DICOM receiver accepts associations with presentation contexts for the SOP Classes of the Storage Service Class. Thus, the DICOM receiver accepts storage requests for Computed Tomography (CT), Magnetic Resonance (MR), Ultrasound (US), Nuclear Medicine (NM), Computed Radiography (CR), and most other modalities. It receives the images and writes them to files in the format specified in DICOM.

C-FIND SCP - The C-FIND service is used by Mach7 Enterprise Imaging Platform when invoked by a DIMSE-service-user to match a series of attribute strings against the attributes of the set of SOP Instances managed by a DIMSE-service-user. The C-FIND service returns a list of requested attributes and their values for each match.

C-ECHO SCP – Mach7 Enterprise Imaging Platform provides standard conformance to the DICOM 3.0 Verification Association establishment policies as defined below:

General - The DICOM Verification routine responds to a verification of communication request from a remote DICOM AE by sending a C-ECHO response to a status of SUCCESS. The maximum PDU size in an association request defaults to 16 kilobytes.

Number of associations - Each verification (C-ECHO) request sent to Mach7 Enterprise Imaging Platform is responded to on an association opened by the remote AE. Multiple associations for the C-ECHO SOP class can be accepted and processed by Mach7 Enterprise Imaging Platform in one working session.

Asynchronous nature - The DICOM verification routine only allows a single outstanding operation on an association. Thus, there is no asynchronous activity in this implementation.

Implementation Identifying Information - The Implementation Class Unique Identifier (UID) is confirmed by the DICOM verification.

C-MOVE SCP - Mach7 Enterprise Imaging Platform SCP shall identify a set of entities at the level of the transfer based upon the values in the unique keys in the identifier of the remote C-MOVE SCU request. The SCP shall then initiate C-STORE SCU sub-operations for the corresponding storage SOP Instances. These C-STORE sub-operations shall occur on a different association from the CMOVE operation. The SCP of the Query/Retrieve Service Class shall serve as an SCU of the Storage Service Class. The SCP shall establish a new association for the C-STORE sub-operations. A sub-operation is considered failed if the SCP is unable to negotiate an appropriate presentation context for a given stored SOP Instance.

C-STORE SCU - This service sends a C-STORE message to a Storage SCP and waits for a response. The application can be used to transmit DICOM images. The C-STORE SCU class performs the C-STORE operation as a user. This class contains a method to send the C-STORE request to the user. If the data set

collection is provided by the user, then this class will create a default C-STORE request of the data set. The class contains the method send which checks whether a session is created. If it is determined that a session has not been created, it creates the session. It then establishes the association and sends the C-STORE request.

C-ECHO SCU - Mach7 Enterprise Imaging Platform implements an SCU for the verification SOP class. It sends a DICOM C-ECHO message to an SCP and waits for a response. The application is used to verify basic DICOM connectivity.

Modality Worklist SCP – This service provides Modality Worklist items based on queries from remote applications. It's implemented as a Mach7 Workflow Engine adapter.

Modality Worklist SCU – This service queries remote applications for Modality Worklist items and provides the results to Mach7 Enterprise Imaging Platform. It is implemented as a Mach7 Workflow Engine adapter and can be used as a building block in configurable clinical workflows.

Printing SCU – Based on user requests it sends images to a remote AE (Printer) for printing on film sheets.

QIDO-RS Service SCP – This service allows clients to search for DICOM studies, series or SOP instances stored in Mach7 Enterprise Imaging Platform archive utilizing the RESTful interface. Remote clients can search for DICOM objects stored in Mach7 Enterprise Imaging Platform using the following action types implemented by this service - SearchForStudies, SearchForSeries, SearchForInstances.

WADO-URI Service SCP – This service implements Web Access to DICOM Persistent Objects using the URI interface. It converts URI parameters into internal lookup functions to find and return matching SOP instances to the remote client.

WADO-RS Service SCP – This service provides Web Access to DICOM Persistent Objects, metadata and bulk data utilizing the RESTful interface. Remote clients can access DICOM SOP instances stored in Mach7 Enterprise Imaging Platform using the following action types implemented by this service - RetrieveStudy, RetrieveSeries, RetrieveInstance, RetrieveFrames, RetrieveBulkdata, RetrieveMetadata.

When Mach7 Enterprise Imaging Platform has received an association request, it will examine the following information in the association request:

- Calling AE Title
- Abstract syntax/Transfer syntax list in the Presentation Context Item
- User Information Item

Mach7 Enterprise Imaging Platform DICOM Workflow

Mach7 Enterprise Imaging Platform has an Access Control List (ACL) database that contains the access control matrix for each DICOM end user. Mach7 Enterprise Imaging Platform matches the data carried by the association request with the data in the ACL database. When Mach7 Enterprise Imaging Platform determines that at least one or more Abstract syntax/Transfer syntax items are allowed for the user, it

will construct the association, acknowledge accordingly and send the ASSOCIATION-AC package back to the requester. Otherwise, it will issue an ASSOCIATION-RJ (association reject) package.

Within a single association, Mach7 Enterprise Imaging Platform will deal with one or more DIMSE service requests until an association release request is received. When Mach7 Enterprise Imaging Platform receives a C-STORE request, it will create a dedicated thread to perform the C-STORE SCP role, receive DICOM image data, and save the data to its archive database.

When Mach7 Enterprise Imaging Platform receives a C-ECHO request, it will act as a C-ECHO SCP, and respond to the requester with a C-ECHO response. When Mach7 Enterprise Imaging Platform receives a C-FIND request, it will create a dedicated thread to handle the request. It uses the identifier data in the C-FIND request to query the database, or use the identifier data to issue another C-FIND request to a third image server. When it receives the data records from the database or the third image server, Mach7 Enterprise Imaging Platform will send the data back to the requester, with one data record in each response data package. It repeats these response packages with a PENDING status until all of them are sent. The last response issued is a SUCCESS status.

When Mach7 Enterprise Imaging Platform receives a C-GET or C-MOVE request, it will create a dedicated thread to handle the request. It uses the identifier data in the request to query the database, or construct another C-MOVE request to query for image objects from a third party image server. When it receives the data records from the database or the third party image server, Mach7 Enterprise Imaging Platform will send these image objects back to the requester or a third specified destination with C-STORE SCU services. After each image object is sent, Mach7 Enterprise Imaging Platform will issue one C-MOVE response package to the requester. The response package may or may not be attached with image information record data, depending upon the way the server is configured. When all images are sent, Mach7 Enterprise Imaging Platform will issue an additional response package with SUCCESS status.

Mach7 Enterprise Imaging Platform issues a DICOM association request for storage service when an internal operation requests to send an image or a series of images to a remote node. When the association is established between Mach7 Enterprise Imaging Platform and a storage service provider, Mach7 Enterprise Imaging Platform starts sending the image data to the storage service provider. When an internal operation demands to query some image information from a remote node, Mach7 Enterprise Imaging Platform will issue a DICOM association request for query/retrieve operations. When the association is established, Mach7 Enterprise Imaging Platform will send one or a set of C-FIND requests to the remote node. When an operation requires getting image data from a remote node, Mach7 Enterprise Imaging Platform will issue one or more C-MOVE requests to the remote node to retrieve the desired images.

Application Entity Specification

Application Entity Title is the representation used to identify the DICOM nodes communicating between each other.

Mach7 Enterprise Imaging Platform AE Specification

Mach7 Enterprise Imaging Platform provides standard conformance to the DICOM 3.0 Services listed below.

Conformance to SOP Classes as SCP (Mach7 Archive) and/or SCU (Mach7 Engine)		
SOP Class Name	SOP Class UID	SCP/SCU Roles
Verification	1.2.840.10008.1.1	SCP/SCU
Computed Radiography Image Storage	1.2.840.10008.5.1.4.1.1.1	SCP/SCU
Digital X-Ray Image Storage - For Presentation	1.2.840.10008.5.1.4.1.1.1.1	SCP/SCU
Digital X-Ray Image Storage - For Processing	1.2.840.10008.5.1.4.1.1.1.1.1	SCP/SCU
Digital Mammography X-Ray Image Storage - For Presentation	1.2.840.10008.5.1.4.1.1.1.2	SCP/SCU
Digital Mammography X-Ray Image Storage - For Processing	1.2.840.10008.5.1.4.1.1.1.2.1	SCP/SCU
Digital Intra-Oral X-Ray Image Storage - For Presentation	1.2.840.10008.5.1.4.1.1.1.3	SCP/SCU
Digital Intra-Oral X-Ray Image Storage - For Processing	1.2.840.10008.5.1.4.1.1.1.3.1	SCP/SCU
CT Image Storage	1.2.840.10008.5.1.4.1.1.2	SCP/SCU
Enhanced CT Image Storage	1.2.840.10008.5.1.4.1.1.2.1	SCP/SCU
Legacy Converted Enhanced CT Image Storage	1.2.840.10008.5.1.4.1.1.2.2	SCP/SCU
Ultrasound Multi-frame Image Storage	1.2.840.10008.5.1.4.1.1.3.1	SCP/SCU
MR Image Storage	1.2.840.10008.5.1.4.1.1.4	SCP/SCU
Enhanced MR Image Storage	1.2.840.10008.5.1.4.1.1.4.1	SCP/SCU
MR Spectroscopy Storage	1.2.840.10008.5.1.4.1.1.4.2	SCP/SCU
Enhanced MR Color Image Storage	1.2.840.10008.5.1.4.1.1.4.3	SCP/SCU
Legacy Converted Enhanced MR Image Storage	1.2.840.10008.5.1.4.1.1.4.4	SCP/SCU
Ultrasound Image Storage	1.2.840.10008.5.1.4.1.1.6.1	SCP/SCU
Enhanced US Volume Storage	1.2.840.10008.5.1.4.1.1.6.2	SCP/SCU
Secondary Capture Image Storage	1.2.840.10008.5.1.4.1.1.7	SCP/SCU
Multi-frame Single Bit Secondary Capture Image Storage	1.2.840.10008.5.1.4.1.1.7.1	SCP/SCU
Multi-frame Grayscale Byte Secondary Capture Image Storage	1.2.840.10008.5.1.4.1.1.7.2	SCP/SCU

Conformance to SOP Classes as SCP (Mach7 Archive) and/or SCU (Mach7 Engine)		
SOP Class Name	SOP Class UID	SCP/SCU Roles
Multi-frame Grayscale Word Secondary Capture Image Storage	1.2.840.10008.5.1.4.1.1.7.3	SCP/SCU
Multi-frame True Color Secondary Capture Image Storage	1.2.840.10008.5.1.4.1.1.7.4	SCP/SCU
12-lead ECG Waveform Storage	1.2.840.10008.5.1.4.1.1.9.1.1	SCP/SCU
General ECG Waveform Storage	1.2.840.10008.5.1.4.1.1.9.1.2	SCP/SCU
Ambulatory ECG Waveform Storage	1.2.840.10008.5.1.4.1.1.9.1.3	SCP/SCU
Hemodynamic Waveform Storage	1.2.840.10008.5.1.4.1.1.9.2.1	SCP/SCU
Cardiac Electrophysiology Waveform Storage	1.2.840.10008.5.1.4.1.1.9.3.1	SCP/SCU
Basic Voice Audio Waveform Storage	1.2.840.10008.5.1.4.1.1.9.4.1	SCP/SCU
General Audio Waveform Storage	1.2.840.10008.5.1.4.1.1.9.4.2	SCP/SCU
Arterial Pulse Waveform Storage	1.2.840.10008.5.1.4.1.1.9.5.1	SCP/SCU
Respiratory Waveform Storage	1.2.840.10008.5.1.4.1.1.9.6.1	SCP/SCU
Multi-channel Respiratory Waveform Storage	1.2.840.10008.5.1.4.1.1.9.6.2	SCP/SCU
Routine Scalp Electroencephalogram Waveform Storage	1.2.840.10008.5.1.4.1.1.9.7.1	SCP/SCU
Electromyogram Waveform Storage	1.2.840.10008.5.1.4.1.1.9.7.2	SCP/SCU
Electrooculogram Waveform Storage	1.2.840.10008.5.1.4.1.1.9.7.3	SCP/SCU
Sleep Electroencephalogram Waveform Storage	1.2.840.10008.5.1.4.1.1.9.7.4	SCP/SCU
Body Position Waveform Storage	1.2.840.10008.5.1.4.1.1.9.8.1	SCP/SCU
Grayscale Softcopy Presentation State Storage	1.2.840.10008.5.1.4.1.1.11.1	SCP/SCU
Color Softcopy Presentation State Storage	1.2.840.10008.5.1.4.1.1.11.2	SCP/SCU
Pseudo-Color Softcopy Presentation State Storage	1.2.840.10008.5.1.4.1.1.11.3	SCP/SCU
Blending Softcopy Presentation State Storage	1.2.840.10008.5.1.4.1.1.11.4	SCP/SCU
XA/XRF Grayscale Softcopy Presentation State Storage	1.2.840.10008.5.1.4.1.1.11.5	SCP/SCU
Grayscale Planar MPR Volumetric Presentation State Storage	1.2.840.10008.5.1.4.1.1.11.6	SCP/SCU
Compositing Planar MPR Volumetric Presentation State Storage	1.2.840.10008.5.1.4.1.1.11.7	SCP/SCU
Advanced Blending Presentation State Storage	1.2.840.10008.5.1.4.1.1.11.8	SCP/SCU
Volume Rendering Volumetric Presentation State Storage	1.2.840.10008.5.1.4.1.1.11.9	SCP/SCU

Conformance to SOP Classes as SCP (Mach7 Archive) and/or SCU (Mach7 Engine)		
SOP Class Name	SOP Class UID	SCP/SCU Roles
Segmented Volume Rendering Volumetric Presentation State Storage	1.2.840.10008.5.1.4.1.1.11.10	SCP/SCU
Multiple Volume Rendering Volumetric Presentation State Storage	1.2.840.10008.5.1.4.1.1.11.11	SCP/SCU
X-Ray Angiographic Image Storage	1.2.840.10008.5.1.4.1.1.12.1	SCP/SCU
Enhanced XA Image Storage	1.2.840.10008.5.1.4.1.1.12.1.1	SCP/SCU
X-Ray Radiofluoroscopic Image Storage	1.2.840.10008.5.1.4.1.1.12.2	SCP/SCU
Enhanced XRF Image Storage	1.2.840.10008.5.1.4.1.1.12.2.1	SCP/SCU
X-Ray 3D Angiographic Image Storage	1.2.840.10008.5.1.4.1.1.13.1.1	SCP/SCU
X-Ray 3D Craniofacial Image Storage	1.2.840.10008.5.1.4.1.1.13.1.2	SCP/SCU
Breast Tomosynthesis Image Storage	1.2.840.10008.5.1.4.1.1.13.1.3	SCP/SCU
Breast Projection X-Ray Image Storage - For Presentation	1.2.840.10008.5.1.4.1.1.13.1.4	SCP/SCU
Breast Projection X-Ray Image Storage - For Processing	1.2.840.10008.5.1.4.1.1.13.1.5	SCP/SCU
Intravascular Optical Coherence Tomography Image Storage - For Presentation	1.2.840.10008.5.1.4.1.1.14.1	SCP/SCU
Intravascular Optical Coherence Tomography Image Storage - For Processing	1.2.840.10008.5.1.4.1.1.14.2	SCP/SCU
Nuclear Medicine Image Storage	1.2.840.10008.5.1.4.1.1.20	SCP/SCU
Parametric Map Storage	1.2.840.10008.5.1.4.1.1.30	SCP/SCU
Raw Data Storage	1.2.840.10008.5.1.4.1.1.66	SCP/SCU
Spatial Registration Storage	1.2.840.10008.5.1.4.1.1.66.1	SCP/SCU
Spatial Fiducials Storage	1.2.840.10008.5.1.4.1.1.66.2	SCP/SCU
Deformable Spatial Registration Storage	1.2.840.10008.5.1.4.1.1.66.3	SCP/SCU
Segmentation Storage	1.2.840.10008.5.1.4.1.1.66.4	SCP/SCU
Surface Segmentation Storage	1.2.840.10008.5.1.4.1.1.66.5	SCP/SCU
Tractography Results Storage	1.2.840.10008.5.1.4.1.1.66.6	SCP/SCU
Real World Value Mapping Storage	1.2.840.10008.5.1.4.1.1.67	SCP/SCU
Surface Scan Mesh Storage	1.2.840.10008.5.1.4.1.1.68.1	SCP/SCU
Surface Scan Point Cloud Storage	1.2.840.10008.5.1.4.1.1.68.2	SCP/SCU
VL Endoscopic Image Storage	1.2.840.10008.5.1.4.1.1.77.1.1	SCP/SCU
Video Endoscopic Image Storage	1.2.840.10008.5.1.4.1.1.77.1.1.1	SCP/SCU
VL Microscopic Image Storage	1.2.840.10008.5.1.4.1.1.77.1.2	SCP/SCU
Video Microscopic Image Storage	1.2.840.10008.5.1.4.1.1.77.1.2.1	SCP/SCU
VL Slide-Coordinates Microscopic Image Storage	1.2.840.10008.5.1.4.1.1.77.1.3	SCP/SCU
VL Photographic Image Storage	1.2.840.10008.5.1.4.1.1.77.1.4	SCP/SCU
Video Photographic Image Storage	1.2.840.10008.5.1.4.1.1.77.1.4.1	SCP/SCU

Conformance to SOP Classes as SCP (Mach7 Archive) and/or SCU (Mach7 Engine)		
SOP Class Name	SOP Class UID	SCP/SCU Roles
Ophthalmic Photography 8 Bit Image Storage	1.2.840.10008.5.1.4.1.1.77.1.5.1	SCP/SCU
Ophthalmic Photography 16 Bit Image Storage	1.2.840.10008.5.1.4.1.1.77.1.5.2	SCP/SCU
Stereometric Relationship Storage	1.2.840.10008.5.1.4.1.1.77.1.5.3	SCP/SCU
Ophthalmic Tomography Image Storage	1.2.840.10008.5.1.4.1.1.77.1.5.4	SCP/SCU
Wide Field Ophthalmic Photography Stereographic Projection Image Storage	1.2.840.10008.5.1.4.1.1.77.1.5.5	SCP/SCU
Wide Field Ophthalmic Photography 3D Coordinates Image Storage	1.2.840.10008.5.1.4.1.1.77.1.5.6	SCP/SCU
Ophthalmic Optical Coherence Tomography En Face Image Storage	1.2.840.10008.5.1.4.1.1.77.1.5.7	SCP/SCU
Ophthalmic Optical Coherence Tomography B-scan Volume Analysis Storage	1.2.840.10008.5.1.4.1.1.77.1.5.8	SCP/SCU
VL Whole Slide Microscopy Image Storage	1.2.840.10008.5.1.4.1.1.77.1.6	SCP/SCU
Dermoscopic Photography Image Storage	1.2.840.10008.5.1.4.1.1.77.1.7	SCP/SCU
Lensometry Measurements Storage	1.2.840.10008.5.1.4.1.1.78.1	SCP/SCU
Autorefractive Measurements Storage	1.2.840.10008.5.1.4.1.1.78.2	SCP/SCU
Keratometry Measurements Storage	1.2.840.10008.5.1.4.1.1.78.3	SCP/SCU
Subjective Refraction Measurements Storage	1.2.840.10008.5.1.4.1.1.78.4	SCP/SCU
Visual Acuity Measurements Storage	1.2.840.10008.5.1.4.1.1.78.5	SCP/SCU
Spectacle Prescription Report Storage	1.2.840.10008.5.1.4.1.1.78.6	SCP/SCU
Ophthalmic Axial Measurements Storage	1.2.840.10008.5.1.4.1.1.78.7	SCP/SCU
Intraocular Lens Calculations Storage	1.2.840.10008.5.1.4.1.1.78.8	SCP/SCU
Macular Grid Thickness and Volume Report	1.2.840.10008.5.1.4.1.1.79.1	SCP/SCU
Ophthalmic Visual Field Static Perimetry Measurements Storage	1.2.840.10008.5.1.4.1.1.80.1	SCP/SCU
Ophthalmic Thickness Map Storage	1.2.840.10008.5.1.4.1.1.81.1	SCP/SCU
Corneal Topography Map Storage	1.2.840.10008.5.1.4.1.1.82.1	SCP/SCU
Basic Text SR Storage	1.2.840.10008.5.1.4.1.1.88.11	SCP/SCU
Enhanced SR Storage	1.2.840.10008.5.1.4.1.1.88.22	SCP/SCU
Comprehensive SR Storage	1.2.840.10008.5.1.4.1.1.88.33	SCP/SCU
Comprehensive 3D SR Storage	1.2.840.10008.5.1.4.1.1.88.34	SCP/SCU
Extensible SR Storage	1.2.840.10008.5.1.4.1.1.88.35	SCP/SCU
Procedure Log Storage	1.2.840.10008.5.1.4.1.1.88.40	SCP/SCU

Conformance to SOP Classes as SCP (Mach7 Archive) and/or SCU (Mach7 Engine)		
SOP Class Name	SOP Class UID	SCP/SCU Roles
Mammography CAD SR Storage	1.2.840.10008.5.1.4.1.1.88.50	SCP/SCU
Key Object Selection Document Storage	1.2.840.10008.5.1.4.1.1.88.59	SCP/SCU
Chest CAD SR Storage	1.2.840.10008.5.1.4.1.1.88.65	SCP/SCU
X-Ray Radiation Dose SR Storage	1.2.840.10008.5.1.4.1.1.88.67	SCP/SCU
Radiopharmaceutical Radiation Dose SR Storage	1.2.840.10008.5.1.4.1.1.88.68	SCP/SCU
Colon CAD SR Storage	1.2.840.10008.5.1.4.1.1.88.69	SCP/SCU
Implantation Plan SR Document Storage	1.2.840.10008.5.1.4.1.1.88.70	SCP/SCU
Acquisition Context SR Storage	1.2.840.10008.5.1.4.1.1.88.71	SCP/SCU
Simplified Adult Echo SR Storage	1.2.840.10008.5.1.4.1.1.88.72	SCP/SCU
Patient Radiation Dose SR Storage	1.2.840.10008.5.1.4.1.1.88.73	SCP/SCU
Planned Imaging Agent Administration SR Storage	1.2.840.10008.5.1.4.1.1.88.74	SCP/SCU
Performed Imaging Agent Administration SR Storage	1.2.840.10008.5.1.4.1.1.88.75	SCP/SCU
Enhanced X-Ray Radiation Dose SR Storage	1.2.840.10008.5.1.4.1.1.88.76	SCP/SCU
Content Assessment Results Storage	1.2.840.10008.5.1.4.1.1.90.1	SCP/SCU
Microscopy Bulk Simple Annotations Storage	1.2.840.10008.5.1.4.1.1.91.1	SCP/SCU
Encapsulated PDF Storage	1.2.840.10008.5.1.4.1.1.104.1	SCP/SCU
Encapsulated CDA Storage	1.2.840.10008.5.1.4.1.1.104.2	SCP/SCU
Encapsulated STL Storage	1.2.840.10008.5.1.4.1.1.104.3	SCP/SCU
Encapsulated OBJ Storage	1.2.840.10008.5.1.4.1.1.104.4	SCP/SCU
Encapsulated MTL Storage	1.2.840.10008.5.1.4.1.1.104.5	SCP/SCU
Positron Emission Tomography Image Storage	1.2.840.10008.5.1.4.1.1.128	SCP/SCU
Enhanced PET Image Storage	1.2.840.10008.5.1.4.1.1.130	SCP/SCU
Legacy Converted Enhanced PET Image Storage	1.2.840.10008.5.1.4.1.1.128.1	SCP/SCU
Basic Structured Display Storage	1.2.840.10008.5.1.4.1.1.131	SCP/SCU
CT Performed Procedure Protocol Storage	1.2.840.10008.5.1.4.1.1.200.2	SCP/SCU
XA Performed Procedure Protocol Storage	1.2.840.10008.5.1.4.1.1.200.8	SCP/SCU
RT Image Storage	1.2.840.10008.5.1.4.1.1.481.1	SCP/SCU
RT Dose Storage	1.2.840.10008.5.1.4.1.1.481.2	SCP/SCU
RT Structure Set Storage	1.2.840.10008.5.1.4.1.1.481.3	SCP/SCU
RT Beams Treatment Record Storage	1.2.840.10008.5.1.4.1.1.481.4	SCP/SCU
RT Plan Storage	1.2.840.10008.5.1.4.1.1.481.5	SCP/SCU
RT Brachy Treatment Record Storage	1.2.840.10008.5.1.4.1.1.481.6	SCP/SCU

Conformance to SOP Classes as SCP (Mach7 Archive) and/or SCU (Mach7 Engine)		
SOP Class Name	SOP Class UID	SCP/SCU Roles
RT Treatment Summary Record Storage	1.2.840.10008.5.1.4.1.1.481.7	SCP/SCU
RT Ion Plan Storage	1.2.840.10008.5.1.4.1.1.481.8	SCP/SCU
RT Ion Beams Treatment Record Storage	1.2.840.10008.5.1.4.1.1.481.9	SCP/SCU
RT Physician Intent Storage	1.2.840.10008.5.1.4.1.1.481.10	SCP/SCU
RT Segment Annotation Storage	1.2.840.10008.5.1.4.1.1.481.11	SCP/SCU
RT Radiation Set Storage	1.2.840.10008.5.1.4.1.1.481.12	SCP/SCU
C-Arm Photon-Electron Radiation Storage	1.2.840.10008.5.1.4.1.1.481.13	SCP/SCU
Tomotherapeutic Radiation Storage	1.2.840.10008.5.1.4.1.1.481.14	SCP/SCU
Robotic-Arm Radiation Storage	1.2.840.10008.5.1.4.1.1.481.15	SCP/SCU
RT Radiation Record Set Storage	1.2.840.10008.5.1.4.1.1.481.16	SCP/SCU
RT Radiation Salvage Record Storage	1.2.840.10008.5.1.4.1.1.481.17	SCP/SCU
Tomotherapeutic Radiation Record Storage	1.2.840.10008.5.1.4.1.1.481.18	SCP/SCU
C-Arm Photon-Electron Radiation Record Storage	1.2.840.10008.5.1.4.1.1.481.19	SCP/SCU
Robotic Radiation Record Storage	1.2.840.10008.5.1.4.1.1.481.20	SCP/SCU
RT Radiation Set Delivery Instruction Storage	1.2.840.10008.5.1.4.1.1.481.21	SCP/SCU
RT Treatment Preparation Storage	1.2.840.10008.5.1.4.1.1.481.22	SCP/SCU
RT Beams Delivery Instruction Storage	1.2.840.10008.5.1.4.34.7	SCP/SCU
RT Brachy Application Setup Delivery Instruction Storage	1.2.840.10008.5.1.4.34.10	SCP/SCU
Structured Report Text Storage (Retired)	1.2.840.10008.5.1.4.1.1.88.1	SCP/SCU
Structured Report Audio Storage (Retired)	1.2.840.10008.5.1.4.1.1.88.2	SCP/SCU
Structured Report Detail Storage (Retired)	1.2.840.10008.5.1.4.1.1.88.3	SCP/SCU
Structured Report Comprehensive Storage (Retired)	1.2.840.10008.5.1.4.1.1.88.4	SCP/SCU

Query/Retrieve Specifications

Mach7 Enterprise Imaging Platform provides Standard Conformance to the following DICOM v3.0 SOP Classes related to query/retrieve operations:

SOP Class Name	SOP Class UID	SCP/SCU Roles
Modality Worklist Information Model - FIND	1.2.840.10008.5.1.4.31	SCP/SCU

SOP Class Name	SOP Class UID	SCP/SCU Roles
Patient Root Q/R Information Model – FIND	1.2.840.10008.5.1.4.1.2.1.1	SCP/SCU
Patient Root Q/R Information Model - MOVE	1.2.840.10008.5.1.4.1.2.1.2	SCP/SCU
Study Root Q/R Information Model - FIND	1.2.840.10008.5.1.4.1.2.2.1	SCP/SCU
Study Root Q/R Information Model - MOVE	1.2.840.10008.5.1.4.1.2.2.2	SCP/SCU

Printing Specifications

Mach7 Enterprise Imaging Platform provides Standard Conformance to the following DICOM v3.0 SOP Classes:

SOP Class Name	SOP Class UID	SCP/SCU Roles
Basic Grayscale Print Management Meta	1.2.840.10008.5.1.1.9	SCU

WADO-URI Specifications

The base URL for Mach7 WADO-URI service is: [http\(s\)://<server>/ClinicalStudio/WADO/WADO.aspx](http(s)://<server>/ClinicalStudio/WADO/WADO.aspx)

Supported URL Parameters

Description	Name	Optionality	Requested Object Type	Comments
Request type	requestType	REQUIRED	ALL	Allowed value: "WADO".
Unique identifier of the study	studyUID	REQUIRED	ALL	
Unique identifier of the series	seriesUID	REQUIRED	ALL	
Unique identifier of the object	objectUID	REQUIRED	ALL	
MIME type of the response	contentType	OPTIONAL	ALL	
Image Quality	imageQuality	OPTIONAL	ALL	
Transfer Syntax UID	transferSyntax	OPTIONAL	DICOM	
Anonymize object	anonymize	OPTIONAL	DICOM	Allowed value: "YES"
Annotation on the Object	annotation	OPTIONAL	NON-DICOM	Allowed values: 'patient', 'technique' or both
Number of pixel rows	rows	OPTIONAL	NON-DICOM	
Number of pixel columns	columns	OPTIONAL	NON-DICOM	
Region of the image	region	OPTIONAL	NON-DICOM	
Window center of the image	windowCenter	REQUIRED	NON-DICOM	
Window width of the image	windowWidth	TOGETHER	NON-DICOM	
Frame Number	frameNumber	OPTIONAL	NON-DICOM	

Supported MIME Types:

application/dicom, image/jpeg, image/gif, image/png

WADO-RS Specifications

The base URL for Mach7 WADO-RS service is: ***http(s)://<server>/Mach7Services/WADORS/***

Supported Transfer Syntax UIDs for 'application/dicom' Media Type

Category	Transfer SyntaxUID	Transfer Syntax Name
Single Frame Image	1.2.840.10008.1.2.1	Explicit VR Little Endian
	1.2.840.10008.1.2.4.70	JPEG Lossless, Non-Hierarchical, First-Order Prediction
	1.2.840.10008.1.2.4.50	JPEG Baseline (Process 1)
	1.2.840.10008.1.2.4.51	JPEG Extended (Process 2 & 4)
	1.2.840.10008.1.2.4.57	JPEG Lossless, Non-Hierarchical (Process 14)
	1.2.840.10008.1.2.5	RLE Lossless
	1.2.840.10008.1.2.4.80	JPEG-LS Lossless Image Compression
	1.2.840.10008.1.2.4.81	JPEG-LS Lossy (Near-Lossless) Image Compression
	1.2.840.10008.1.2.4.90	JPEG 2000 Image Compression (Lossless Only)
1.2.840.10008.1.2.4.91	JPEG 2000 Image Compression	
Multi-frame Image	1.2.840.10008.1.2.1	Explicit VR Little Endian
	1.2.840.10008.1.2.4.90	JPEG 2000 Image Compression (Lossless Only)
	1.2.840.10008.1.2.4.91	JPEG 2000 Image Compression
Video	1.2.840.10008.1.2.1	Explicit VR Little Endian

Supported Media Types and Transfer Syntaxes for Uncompressed Pixel Data in Bulk Data Values

Category	Media Type	Transfer SyntaxUID	Transfer Syntax Name
Single Frame Image	application/octet-stream	1.2.840.10008.1.2.1	Explicit VR Little Endian
Multi-frame Image	application/octet-stream	1.2.840.10008.1.2.1	Explicit VR Little Endian
Video	application/octet-stream	1.2.840.10008.1.2.1	Explicit VR Little Endian

Supported Media Types and Transfer Syntaxes for Compressed Pixel Data in Bulk Data Values

Category	Media Type	Transfer SyntaxUID	Transfer Syntax Name
Single Frame Image	image/jpeg	1.2.840.10008.1.2.4.70	JPEG Lossless, Non-Hierarchical, First-Order Prediction
		1.2.840.10008.1.2.4.50	JPEG Baseline (Process 1)
		1.2.840.10008.1.2.4.51	JPEG Extended (Process 2 & 4)
		1.2.840.10008.1.2.4.57	JPEG Lossless, Non-Hierarchical (Process 14)
	image/x-dicom-rle	1.2.840.10008.1.2.5	RLE Lossless

Category	Media Type	Transfer Syntax UID	Transfer Syntax Name
	image/x-jls	1.2.840.10008.1.2.4.80	JPEG-LS Lossless Image Compression
		1.2.840.10008.1.2.4.81	JPEG-LS Lossy (Near-Lossless) Image Compression
	image/jp2	1.2.840.10008.1.2.4.90	JPEG 2000 Image Compression (Lossless Only)
		1.2.840.10008.1.2.4.91	JPEG 2000 Image Compression
Multi-frame Image	image/jpeg	1.2.840.10008.1.2.4.70	JPEG Lossless, Non-Hierarchical, First-Order Prediction
		1.2.840.10008.1.2.4.50	JPEG Baseline (Process 1)
		1.2.840.10008.1.2.4.51	JPEG Extended (Process 2 & 4)
		1.2.840.10008.1.2.4.57	JPEG Lossless, Non-Hierarchical (Process 14)
	image/x-dicom-rle	1.2.840.10008.1.2.5	RLE Lossless
	image/x-jls	1.2.840.10008.1.2.4.80	JPEG-LS Lossless Image Compression
		1.2.840.10008.1.2.4.81	JPEG-LS Lossy (Near-Lossless) Image Compression
	image/jp2	1.2.840.10008.1.2.4.90	JPEG 2000 Image Compression (Lossless Only)
		1.2.840.10008.1.2.4.91	JPEG 2000 Image Compression

Supported WADO-RS Action Types

Mach7 WADO-RS Service supports the following action types as SCP:

- RetrieveStudy
- RetrieveSeries
- RetrieveInstance
- RetrieveFrames
- RetrieveBulkdata
- RetrieveMetadata

Support for 'Rendered' Mode

The following rendered media types are supported by Mach7 WADO-RS service:

- image/jpeg
- image/gif
- image/png

Rendered Transactions which are intended to retrieve multiple rendered instances will only return a single item (rendered instance or frame) along with the Status Code 206 – Partial Content.

WADO-RS HTTP Status Codes

Status Code	Error Name	Error Situation
200	Success	All requested resources has been successfully returned to the caller
206	Partial Content	A subset of the requested resources has been returned to the caller
400	Bad Request	Generic error processing the request
404	Not Found	No records of requested data found
406	Not Acceptable	Accept type, Transfer Syntax or decompression method not supported
409	Conflict	Both DICOM and Rendered media types are present in the request
410	Gone	Specified resource was deleted

QIDO-RS Specifications

Parameter	Specifications
Base URL	http(s)://<server>/Mach7Services/QIDORS/
Media Types	"multipart/related; type=application/dicom+xml" or "application/dicom+json"
Limit and Offset	Not Supported

Supported QIDO-RS Action Types

Mach7 QIDO-RS Service supports the following action types as SCP:

- SearchForStudies
- SearchForSeries
- SearchForInstances

QIDO-RS 'SearchForStudies' Supported URL Specifications

URL	Parameters	Matching	Comments
{Base URL}/studies	PatientID StudyInstanceUID}	Single Unique	At least one of the parameters has to be provided

QIDO-RS 'SearchForStudies' Return Attributes

Attribute Name	Tag
Study Date	(0008,0020)
Study Time	(0008,0030)
Accession Number	(0008,0050)
Modalities in Study	(0008,0061)
Referring Physician's Name	(0008,0090)
Retrieve URL	(0008,1190)
Patient's Name	(0010,0010)
Patient ID	(0010,0020)
Patient's Birth Date	(0010,0030)
Patient's Sex	(0010,0040)
Study Instance UID	(0020,000D)

Attribute Name	Tag
Number of Study Related Series	(0020,1206)
Number of Study Related Instances	(0020,1208)

QIDO-RS 'SearchForSeries' Supported URL Specifications

URL	Parameters	Comments
{Base URL}/studies /{StudyInstanceUID}/series	SeriesInstanceUID	Unique match, optional

QIDO-RS 'SearchForSeries' Return Attributes

Attribute Name	Tag
Modality	(0008,0060)
Series Description	(0008,103E)
Retrieve URL	(0008,1190)
Series Instance UID	(0020,000E)
Series Number	(0020,0011)
Number of Series Related Instances	(0020,1209)

QIDO-RS 'SearchForInstances' Supported URL Specifications

URL	Parameters	Comments
{Base URL}/studies/{StudyInstanceUID}/instances	SOPClassUID	Optional
{Base URL}/studies/{StudyInstanceUID}/series/{SeriesInstanceUID}/instances		

QIDO-RS 'SearchForInstances' Return Attributes

Attribute Name	Tag	Comments
SOP Class UID	(0008,0016)	
SOP Instance UID	(0008,0018)	
Instance Availability	(0008,0056)	
Retrieve URL	(0008,1190)	
Instance Number	(0020,0013)	
Rows	(0028,0010)	Only present for Image Instances
Columns	(0028,0011)	Only present for Image Instances
Bits Allocated	(0028,0100)	Only present for Image Instances
Number of Frames	(0028,0008)	Only present for Multi-frame image instances

QIDO-RS HTTP Status Codes

Status Code	Error Name	Error Situation
200	Success	All requested resources has been successfully returned to the caller
400	Bad Request	Generic error processing the request
406	Not Acceptable	Accept type, Transfer Syntax or decompression method not supported

Association Establishment Policies

General

The DICOM application context is 1.2.840.10008.3.1.1.1

Asynchronous Nature

Mach7 Enterprise Imaging Platform supports asynchronous operations and performs asynchronous window negotiation.

Implementation Identifying Information

Mach7 Enterprise Imaging Platform provides an implementation class UID which is 1.2.826.0.1.3680043.1.1.4.3.82.2

Association Initiation Policy

Mach7 Enterprise Imaging Platform attempts to initiate one association with a remote node in response to each DICOM communication demand raised from internal operations. Any of the conditions listed below will trigger Mach7 Enterprise Imaging Platform to initiate one association.

- When an internal operation attempts to retrieve images from a remote node.
- When an internal operation requests to send a series of images to a remote node.

Associated Real-World Activities

Receive Images from Remote Node

The associated real-world activity is that when Mach7 Enterprise Imaging Platform receives a C-STORE request in an association, it will examine the context ID of the requested package and will receive the image data. After the image data is received, it will perform a data integrity test over the image data. Finally, it will perform an overall structural integrity test over the image data with existing database data. When the image successfully passes all of these tests, it will be stored in Mach7 Enterprise Imaging Platform's image storage. If the image failed at any stage of the tests, it would be stored in a temporary storage and be listed in an error list. The administrative user can access the error list and correct the data with Mach7 Enterprise Imaging Platform's database maintenance utilities.

Respond to a Query/Retrieve Request

The associated real-world activity is as follows. When Mach7 Enterprise Imaging Platform receives a C-FIND, C-GET, or C-MOVE request, it will use the identifier data to query the database, or reconstruct a C-

FIND, C-GET, or C-MOVE request to invoke a request to a third image server. If it is a C-FIND service, when Mach7 Enterprise Imaging Platform receives image information data from the database or the remote node, it will wrap the information into C-FIND response packages. One C-FIND response is for each image record. It repeats C-FIND responses until all records are sent. If it is a C-GET or C-MOVE service, when it receives images from the database or the remote node, it will change its role to C-STORE SCU and issue a C-STORE request to the destination. In C-GET, the destination is the requester. In the C-MOVE service, the destination can be a third party. Furthermore, in C-MOVE, a new association will be initiated for C-STORE operations. After each image object is transmitted, Mach7 Enterprise Imaging Platform issues a C-GET or C-MOVE response back to the requester. The response may or may not have identifier data attached.

Respond to a Storage Commitment Request

The associated real-world activity is that when Mach7 Enterprise Imaging Platform receives a storage commitment request from a remote node, it will perform necessary operations to secure the image objects specified by the request. After the images are considered secure, Mach7 Enterprise Imaging Platform will issue a storage commitment response to the requester. The response may or may not be in the same association as the request. If the response is in a different association, Mach7 Enterprise Imaging Platform will attempt to establish an association with the requester for the storage commitment response (an N-EVENT-REPORT service).

Proposed Presentation Contexts

Mach7 Enterprise Imaging Platform supports the Implicit VR Little Endian transfer syntax (1.2.840.10008.1.2) and Explicit VR Little Endian transfer syntax (1.2.840.10008.1.2.1) for all DICOM DIMSE services. Mach7 Enterprise Imaging Platform supports the following transfer syntaxes for the storage SOP classes, the unique identifiers along with their description are mention in the table below.

Transfer Syntax supported for Image Storage SOP Classes	
UID	Description
1.2.840.10008.1.2	Implicit VR Little Endian
1.2.840.10008.1.2.1	Explicit VR Little Endian
1.2.840.10008.1.2.1.99	Deflated Explicit VR Little Endian
1.2.840.10008.1.2.2	Explicit VR Big Endian
1.2.840.10008.1.2.4.50	JPEG Baseline (Process 1)
1.2.840.10008.1.2.4.51	JPEG Extended (Process 2 & 4)
1.2.840.10008.1.2.4.57	JPEG Lossless, Non-Hierarchical (Process 14)
1.2.840.10008.1.2.4.70	JPEG Lossless, Non-Hierarchical, First-Order Prediction (Process 14 [Selection Value 1])
1.2.840.10008.1.2.4.80	JPEG-LS Lossless Image Compression
1.2.840.10008.1.2.4.81	JPEG-LS Lossy (Near-Lossless) Image Compression
1.2.840.10008.1.2.4.90	JPEG 2000 Image Compression (Lossless Only)
1.2.840.10008.1.2.4.91	JPEG 2000 Image Compression
1.2.840.10008.1.2.4.92	JPEG 2000 Part 2 Multi-component Image Compression (Lossless Only)

Transfer Syntax supported for Image Storage SOP Classes	
UID	Description
1.2.840.10008.1.2.4.93	JPEG 2000 Part 2 Multi-component Image Compression
1.2.840.10008.1.2.4.94	JPIP Referenced
1.2.840.10008.1.2.4.95	JPIP Referenced Deflate
1.2.840.10008.1.2.4.100	MPEG2 Main Profile @ Main Level
1.2.840.10008.1.2.4.101	MPEG2 Main Profile @ High Level
1.2.840.10008.1.2.4.102	MPEG-4 AVC/H.264 High Profile / Level 4.1
1.2.840.10008.1.2.4.103	MPEG-4 AVC/H.264 BD-compatible High Profile / Level 4.1
1.2.840.10008.1.2.5	RLE Lossless
1.2.840.10008.1.2.6.1	RFC 2557 MIME encapsulation
1.2.840.10008.1.2.6.2	XML Encoding

SOP Specific Conformance for Query/Retrieve Service Class

Mach7 Enterprise Imaging Platform supports the most commonly used query/retrieve attributes in its query/retrieve service class. These attributes are listed in the table below.

Supported Query/Retrieve Identifier Attributes			
Tag	Attribute Name	Level	Supported Search Types
0010, 0010	Patient Name	Patient	Wild card (*), universal, exact match
0010, 0020	Patient ID	Patient	Wild card, universal, exact Version
0010, 0030	Patient Date of Birth	Patient	Universal, exact match, range
0010, 0040	Patient Sex	Patient	Universal, exact match
0020, 1200	Total Studies in the Patient	Patient	Universal
0020, 1202	Total Series in the Patient	Patient	Universal
0020, 1204	Total Images in the Patient	Patient	Universal
0008, 0020	Study Date	Study	Universal, exact match, range
0008, 0030	Study Time	Study	Universal, exact match, range
0008, 0050	Accession Number	Study	Wild card, universal, exact match

Supported Query/Retrieve Identifier Attributes			
Tag	Attribute Name	Level	Supported Search Types
0008, 1030	Study Description	Study	Wild card, universal, exact match
0020, 000D	Study Instance UID	Study	Universal, exact match, list
0020, 0010	Study ID	Study	Wild card, universal,
0020, 1206	Total Series in the Study	Study	exact match Universal
0020, 1208	Total Images in the Study	Study	Universal
0008, 0060	Modality	Series	Universal, exact match, list
0020, 000E	Series Instance UID	Series	Universal, exact match, list
0020, 1209	Total Images in the Series	Series	Universal
0010, 0030	Patient Date of Birth	Patient	Universal, exact match, range
0010, 0040	Patient Sex	Patient	Universal, exact match

Communication Profiles

TCP/IP

Mach7 Enterprise Imaging Platform uses the TCP/IP stream socket from Microsoft WinSocket.

Physical Media Support

Mach7 Enterprise Imaging Platform provides no restriction on the physical network. Mach7 Enterprise Imaging Platform can operate using TCP/IP over Ethernet (thick wire, thin wire, 10 BaseT, etc.), FDDI (twisted pair into a concentrator, fiber backbone) and commercial telephone networks.

Support of Extended Character Sets

Mach7 Enterprise Imaging Platform presently provides support for ISO 2022 standardized encoding and also native Unicode Format (UTF-8) and Chinese National Standards GB18030 encodings.